



DISCOVER VALVE

A DIVISION OF DISCOVER TRADING COMPANY INC.

10746 NORTH ARMSTRONG AVENUE, CLOVIS, CALIFORNIA 93619 – PHONE TOLL-FREE 866-9VALVE6

FAX: 559-324-0266 EMAIL: info@discovervalve.com, HTTP://www.discovervalve.com

DUCTILE IRON Y-STRAINERS GROOVED-END 300PSI

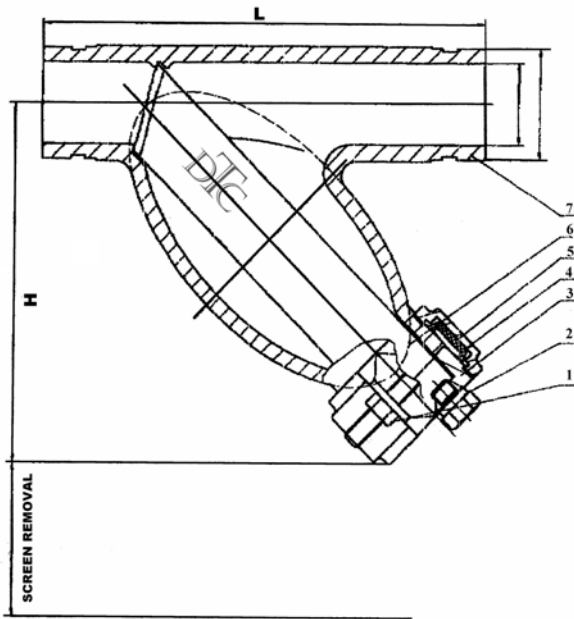

Part	Part Name	Material
1	Coupling Bolt	Zinc Plated Carbon Steel
2	Blow-off Plug	Steel
3	End Cap	ASTM A536
4	Coupling	ASTM A536
5	Gasket	EPDM or Nitrile
6	Screen	304 Stainless Steel
7	Body	ASTM A536

Dimensions (in) and Weights (lbs)

	2"	2 1/2"	3"	4"	6"	8"	10"	12"
L	9.75	10.75	11.75	14.25	18.50	24.00	27.00	30.00
H	7.50	8.30	9.00	11.00	14.40	18.40	22.00	24.75
Screen Removal	4.6	4.8	8.1	6.6	8.6	11.2	12.6	14.4
Weight	10	14	20	32	72	125	205	280

Larger sizes available

DTC reserves the right to modify specifications and/or design parameters without notice.
Updated drawings will be provided with quotation requests if required.